



**MS6720** is an omnidirectional hand-held and fixed projection scanner. It incorporates a 20-line scan pattern into a comfortable, ergonomic style.

## MS6720

### Features

- **Combination hand-held and fixed projection scanner**
- **Fully automatic scanning operation**
- **Stationary or adjustable stand available**
- **Superior ergonomics**
- **Concentrated omnidirectional scan pattern**
- **Programmable depth of field**
- **Easy programming using Windows® software or bar codes**



**Metrologic's MS6720** is the first laser bar code scanner to have bridged the gap between omnidirectional fixed projection and hand-held scanners. It incorporates fixed projection performance and a patented 20-line scan pattern into the comfortable, ergonomic styling of a hand-held. With this design, Metrologic has engineered a scanner that transcends any other on the market today.

The MS6720 utilizes a unique, patented infrared sensor and control scheme for hands-free projection scanning and fatigue reduced hand-held operation. Whether operators choose to present small items to the scanner or transport the lightweight scanner to bulkier items, the MS6720 is the perfect choice for a large variety applications.



The MS6720 scanner is available with either a stationary or adjustable stand. The stationary stand is ideal for applications where the MS6720 is being used mostly as a hand-held scanner. This stand was designed for ease of use while still providing sufficient room for fixed presentation. The adjustable stand provides 7 rotational and 9 tilting positions as well as a removable wall mount cup.

The MS6720 features both short-range and long-range activation, user-friendly programming, reliability and versatility. Operators are sure to appreciate the convenience and flexibility of the MS6720.



# MS6720

## OPERATIONAL

Light Source	Visible Laser Diode 650 nm ± 10 nm
Laser Power	0.681 mW (peak)
Depth of Scan Field (programmable)	0 mm - 203 mm (0" - 8") for 0.330 mm (13 mil) bar code at default setting
Width of Scan Field	50.8 mm (2") @ face; 178 mm (7") @ 203 mm (8")
Scan Speed	1000 scan lines per second
Scan Pattern	5 fields of 4 parallel lines (omnidirectional)
Number of Scan Lines	20
Minimum Bar Width	0.145 mm (5.7 mil)
Decode Capability	Autodiscriminates all standard bar codes; for other symbologies call Metrologic
System Interfaces	PC Keyboard Wedge, RS232, OCIA, Light Pen Emulation, IBM 468X/469X, USB
Print Contrast	35% minimum reflectance difference
Number Characters Read	Up to 80 data characters
Roll, Pitch, Yaw	360°, 60°, 60°
Beeper Operation	3 tones or no beep
Indicators (LED)	Red = laser on, ready to scan Green = good read

## MECHANICAL

Height	216 mm (8.5")
Depth-Handle	28 mm (1.1")
Depth-Head	75 mm (2.9")
Width-Handle	48 mm (1.9")
Width-Head	77 mm (3.0")
Footprint On Stand	100 mm x 135 mm (3.9" x 5.3")
Weight	380 g (13.4 oz)
Termination	10 pin modular, RJ45 connector
Cable	Standard 2.1 m (7') straight; optional 2.7 m (9') coiled; for other cables call Metrologic

## ELECTRICAL

Input Voltage	5 VDC ± 0.25 V
Power	1.1 W @ 5V
Operating Current	220 mA @ 5V
DC Transformers	Class 2; 5 VDC @ 300 mA
Laser Class	CDRH: Class IIa; EN60825-1:1994/A11:1996 Class 1
EMC	FCC, ICES-003 & EN55022 Class B

## ENVIRONMENTAL

Operating Temperature	0°C to 40°C (32°F to 104°F)
Storage Temperature	-40°C to 60°C (-40°F to 140°F)
Humidity	5% to 95% relative humidity, non-condensing
Light Levels	Up to 4842 Lux (450 footcandles)
Shock	Designed to withstand 1 m (3.1') drops
Contaminants	Sealed to resist airborne particulate contaminants
Ventilation	None required

## Scan Area

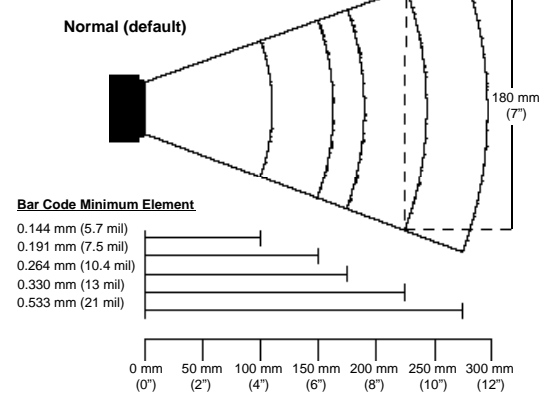

## Dimensions

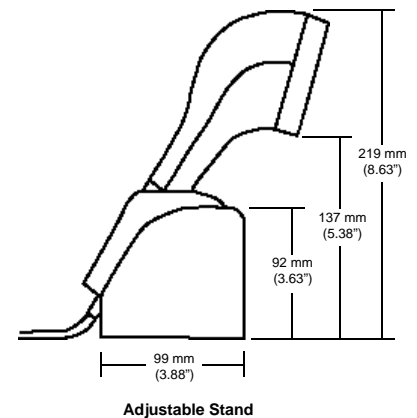
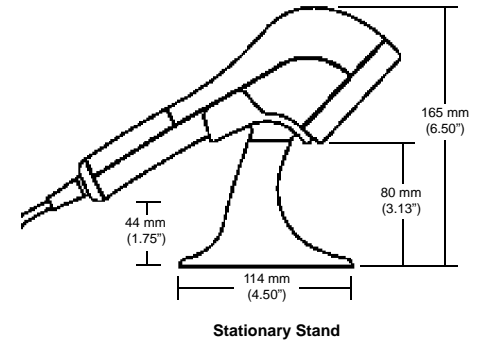

www.metrologic.com

**USA**  
Tel. 1.800.ID.METRO  
info@metrologic.com

**Asia**  
Tel. 65.842.7155  
info@sg.metrologic.com

**AOA (only)**  
Tel. 1.617.806.1400  
info@aoa.metrologic.com

**China (only)**  
Tel. 86.512.2572511  
info@cn.metrologic.com

**South America**  
Tel. 5511.5505.6568  
info@sa.metrologic.com

**Japan (only)**  
Tel. 81.03.3839.8511  
info@jp.metrologic.com

**Brazil (only)**  
Tel. 5511.5505.2396  
info@br.metrologic.com

**Europe**  
Tel. 49.89.89019.0  
info@europe.metrologic.com

Specifications subject to change without notice.  
Printed U.S.A., Copyright June 2001  
Metrologic, All rights reserved.



DS6720

Metrologic Instruments, Inc. | 90 Coles Road | Blackwood, NJ 08012-4683  
Telephone 856-228-8100 or 1-800-ID-METRO | Fax 856-228-6673